



WORLD TOWER COMPANY, INC.

1213 Compressor Drive
P.O. Box 508
Mayfield, KY 42066

Phone: 270-247-3642
Fax: 270-247-0909

WWW.WORLDTOWER.COM



ADVANTAGES OVER CONVENTIONAL BOOM MOUNTS:

- *Vertical and Horizontal Adjustments for Precise Location of Instrumentation*
- *Variable Horizontal Lengths and Pipe Diameter to Meet Design Requirements*
- *Retractable Horizontal Pipe for Easy Instrumentation Repairs*
- *Horizontal Pipe Designed for Minimal Instrumentation Deflection and allowing more accurate Readings*
- *Designed to Insure Factory Fit to World Tower Company, Inc. Towers.*

Double Side Instrument Mount

48.26mm O.D. (STANDARD 2" O.D. PIPE)
UP TO 3M IN LENGTH
(1 REQ'D.)

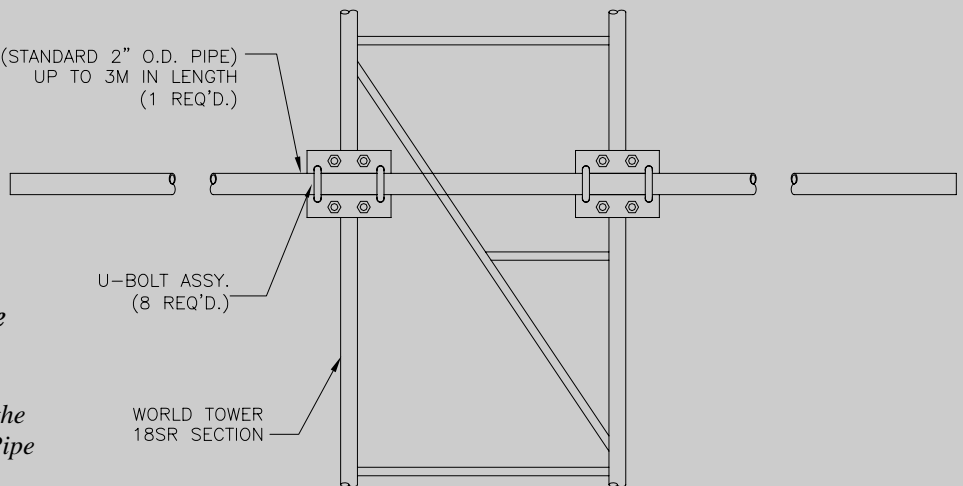

Vertical Instrument Attachment Pipe Optional

- *Used to attach the Instruments to the ends of the Horizontal Mounting Pipe*
- *Pipe length up to 1.5M*



48.26mm O.D. (STANDARD 2" O.D. PIPE)
UP TO 3M IN LENGTH
(1 REQ'D.)

